

MODEL	DESCRIPTION	APPROX. WT. LBS [Kg]
M4105A5.1	126 KW. E @ 1800 RPM (60HZ), HEAT EXCHANGED	2636 [1195]

*NOTE: WEIGHT INCLUDES OIL, BUT NO COOLANT. VALUES ARE APPROXIMATIONS AND ARE SUBJECT TO CHANGE. PLEASE CONTACT NLI TO BE SURE YOU HAVE THE LATEST REVISION.

ITEM	DESCRIPTION	ITEM	DESCRIPTION
1	SEAWATER INLET Ø 2.0 H.B.	14	ENGINE OIL FILL
2	HEAT EXCHANGER	15	FUEL RETURN PORT (3/8" NPT)
3	COOLANT FILL	16	FUEL SUPPLY PORT (3/8" NPT)
4	AFTERCOOLER	17	OIL DRAIN PORT (1/2" NPT)
5	OPTIONAL WET EXHAUST ELBOW	18	ALTERNATOR
6	ELECTRIC STARTER MOTOR	19	OPTIONAL DRY EXHAUST ELBOW
7	EXPANSION TANK	20	
8	THERMOSTAT HOUSING	21	
9	FUEL/WATER SEPERATOR	22	
10	PRIMARY FUEL FILTER	23	
11	OIL FILTER	24	
12	AIR FILTER & COALESCING FILTER	25	
13	ENGINE OIL DIPSTICK	26	

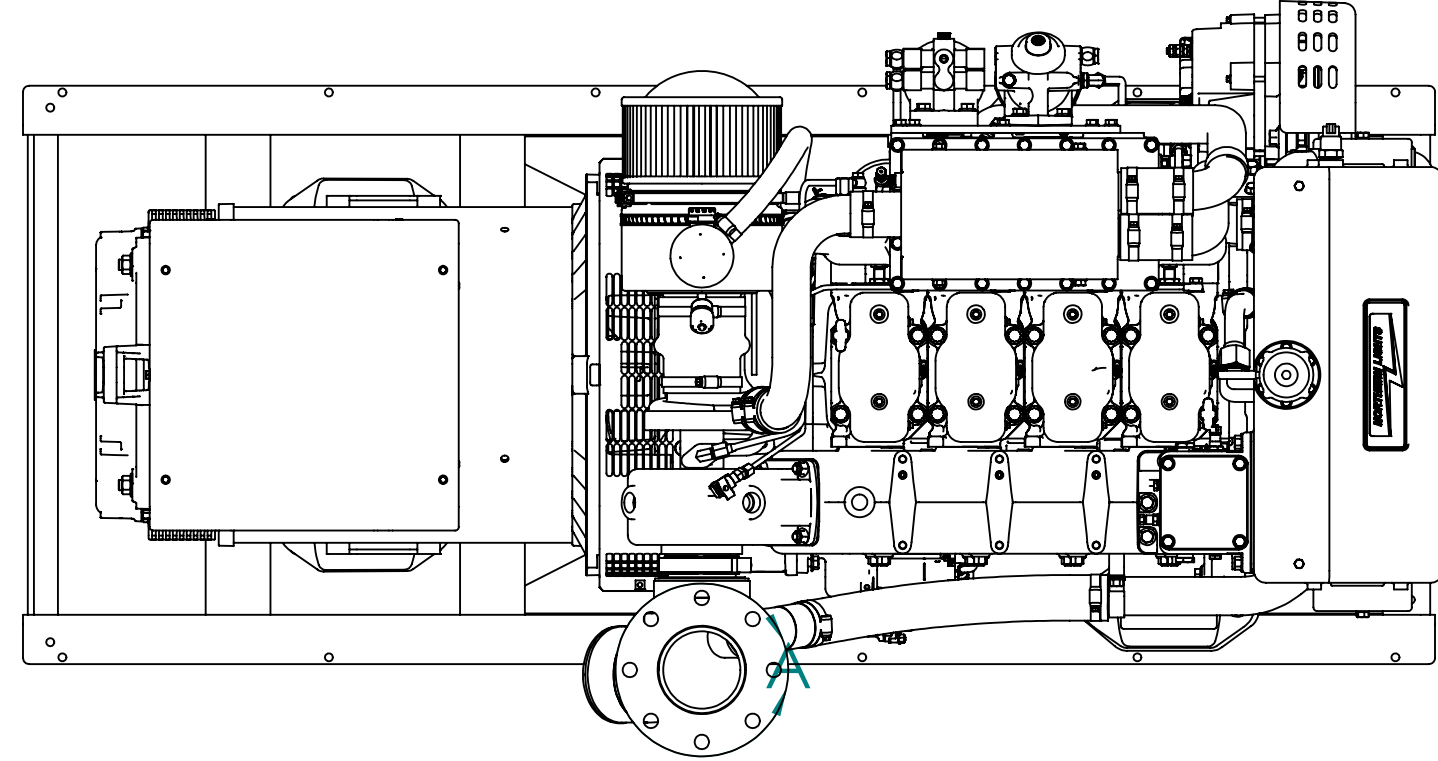

TOP

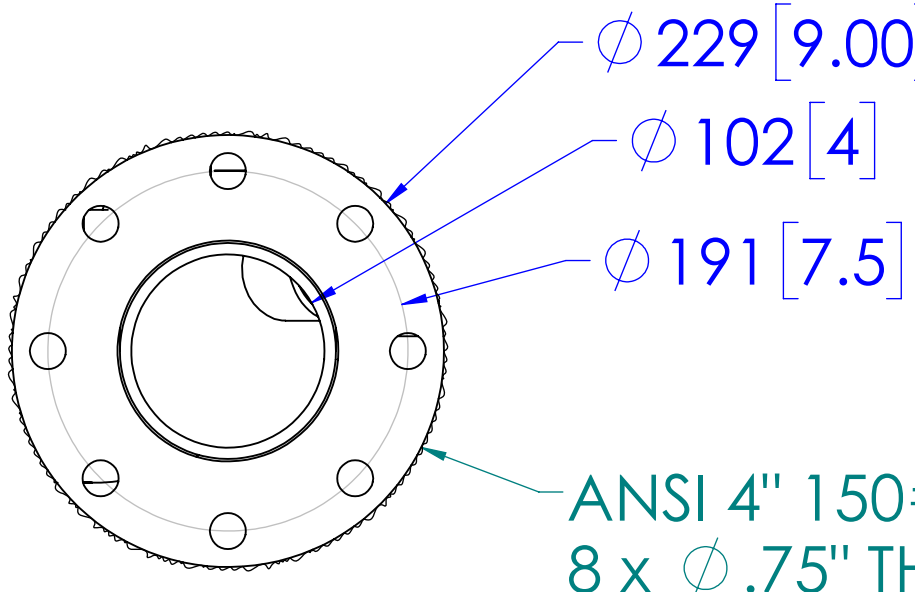

DETAIL A
OPTIONAL DRY EXHAUST FLANGE
SCALE 1 : 4

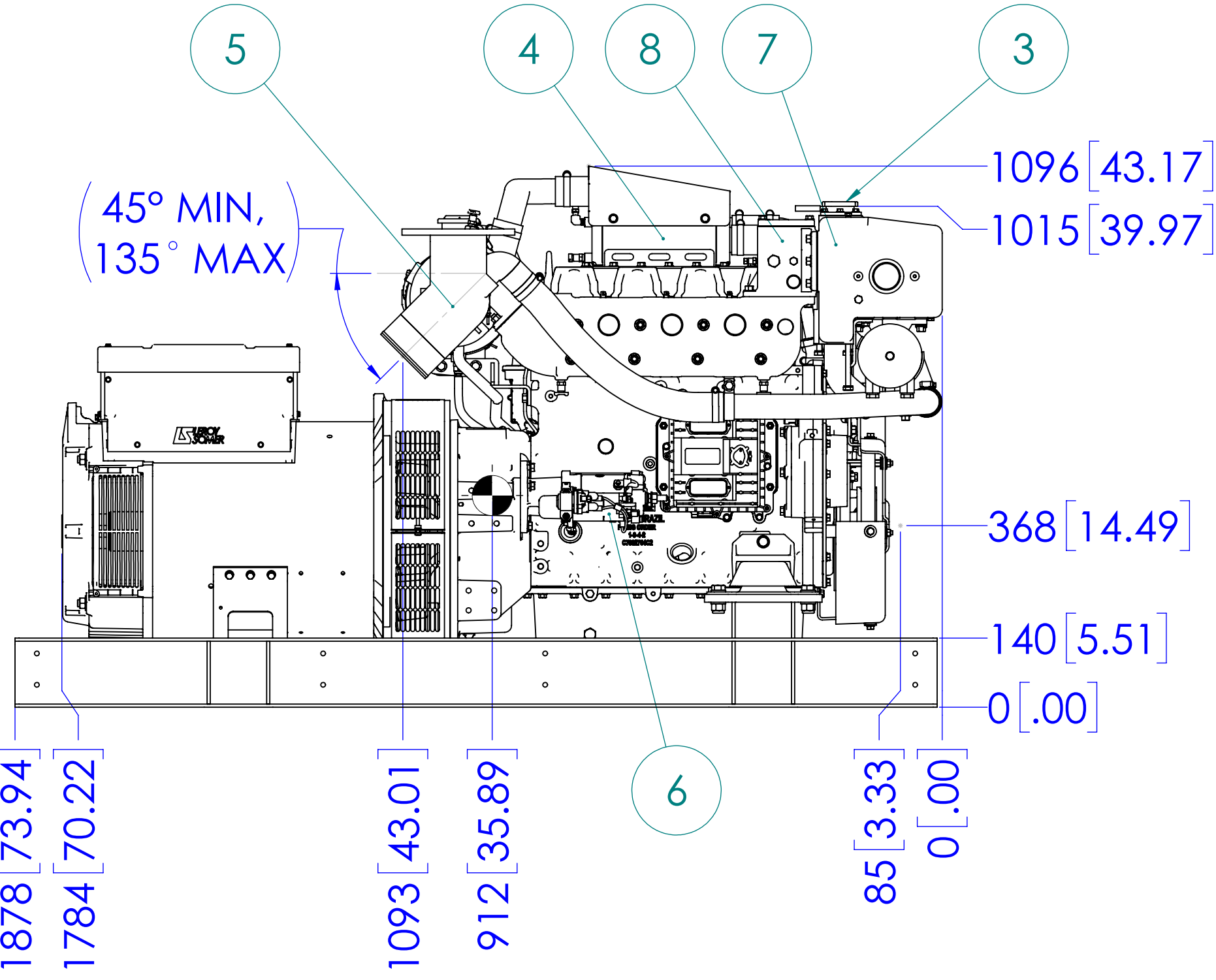

LEFT SIDE

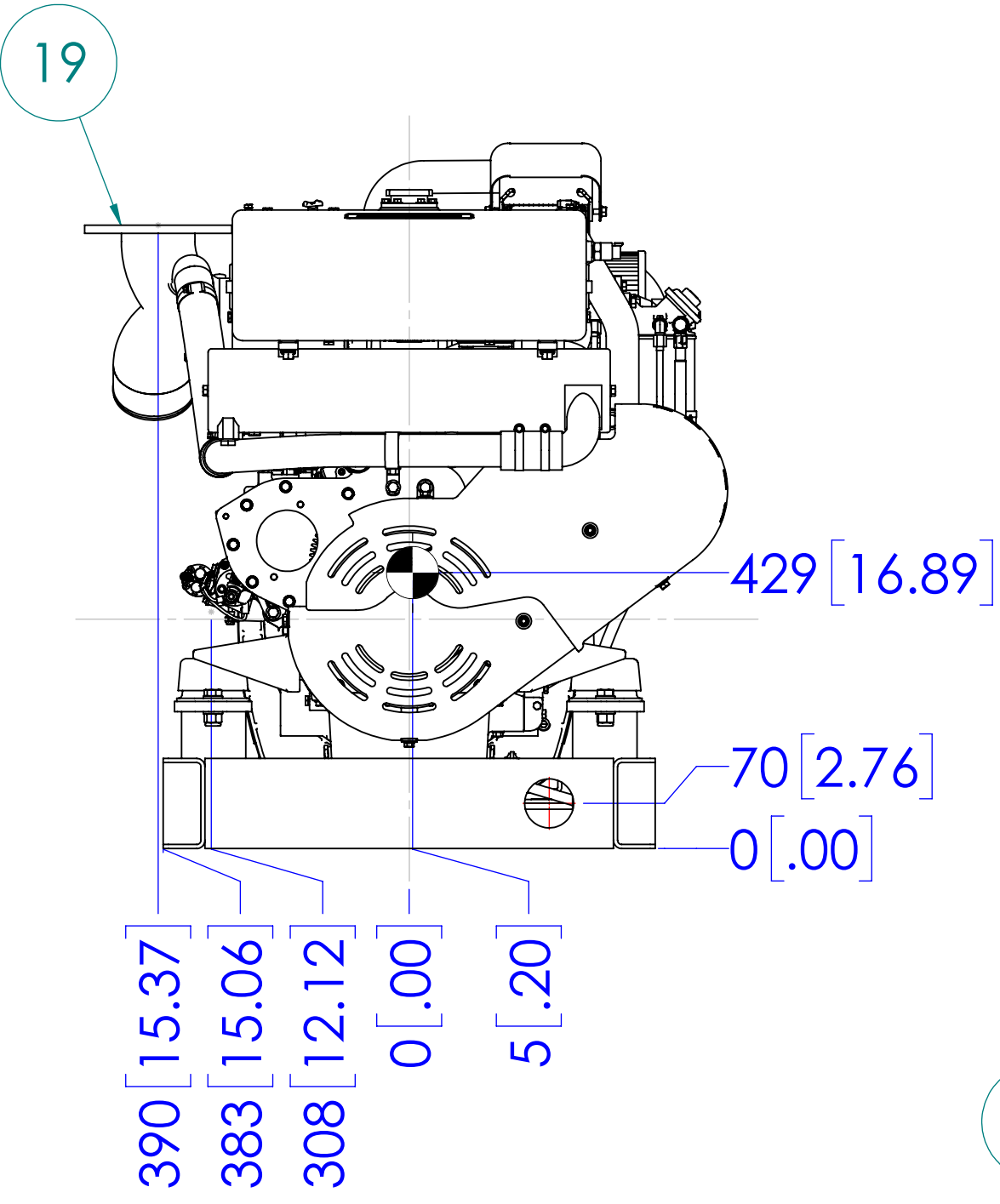

FRONT

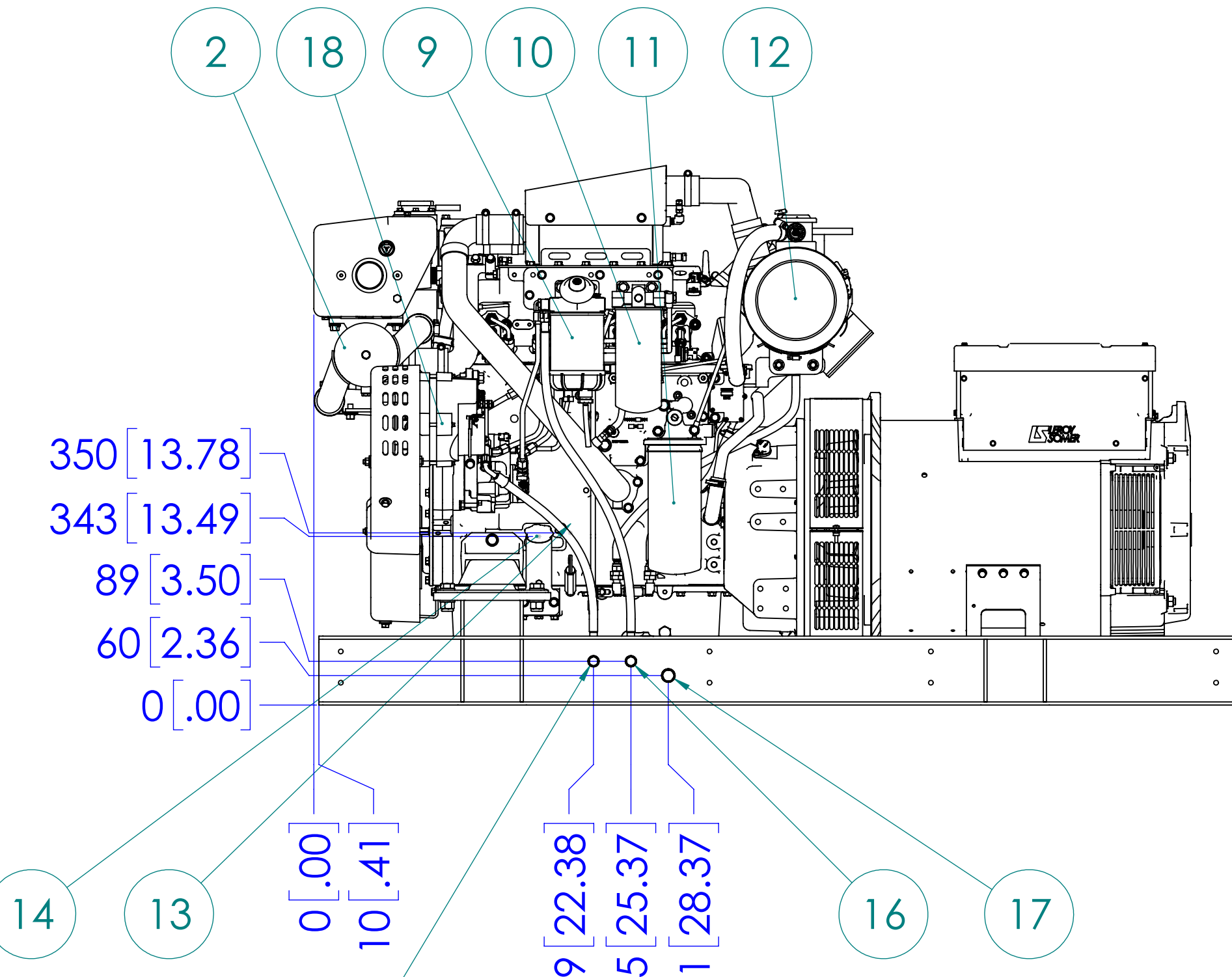

SERVICE SIDE

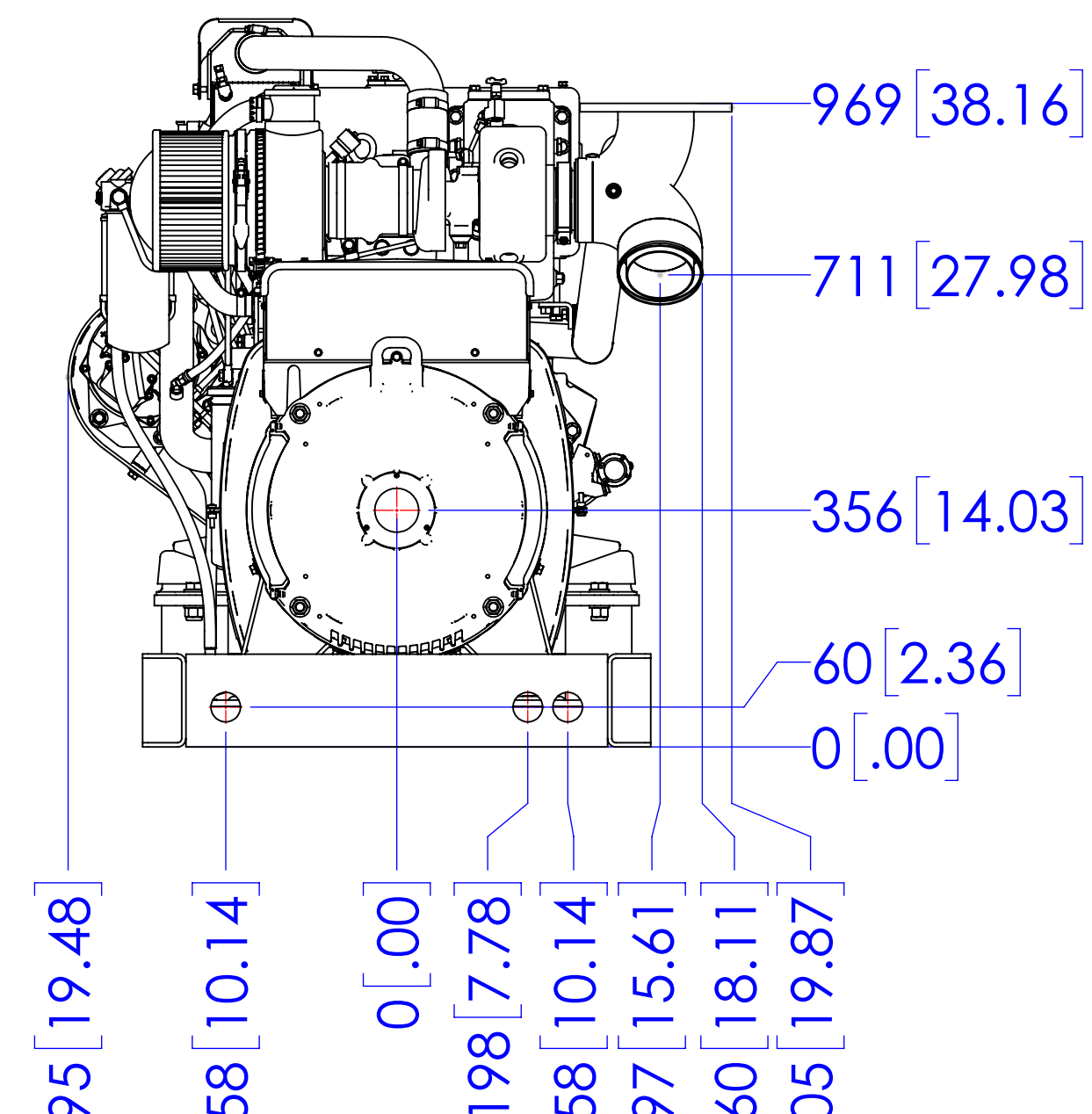

REAR

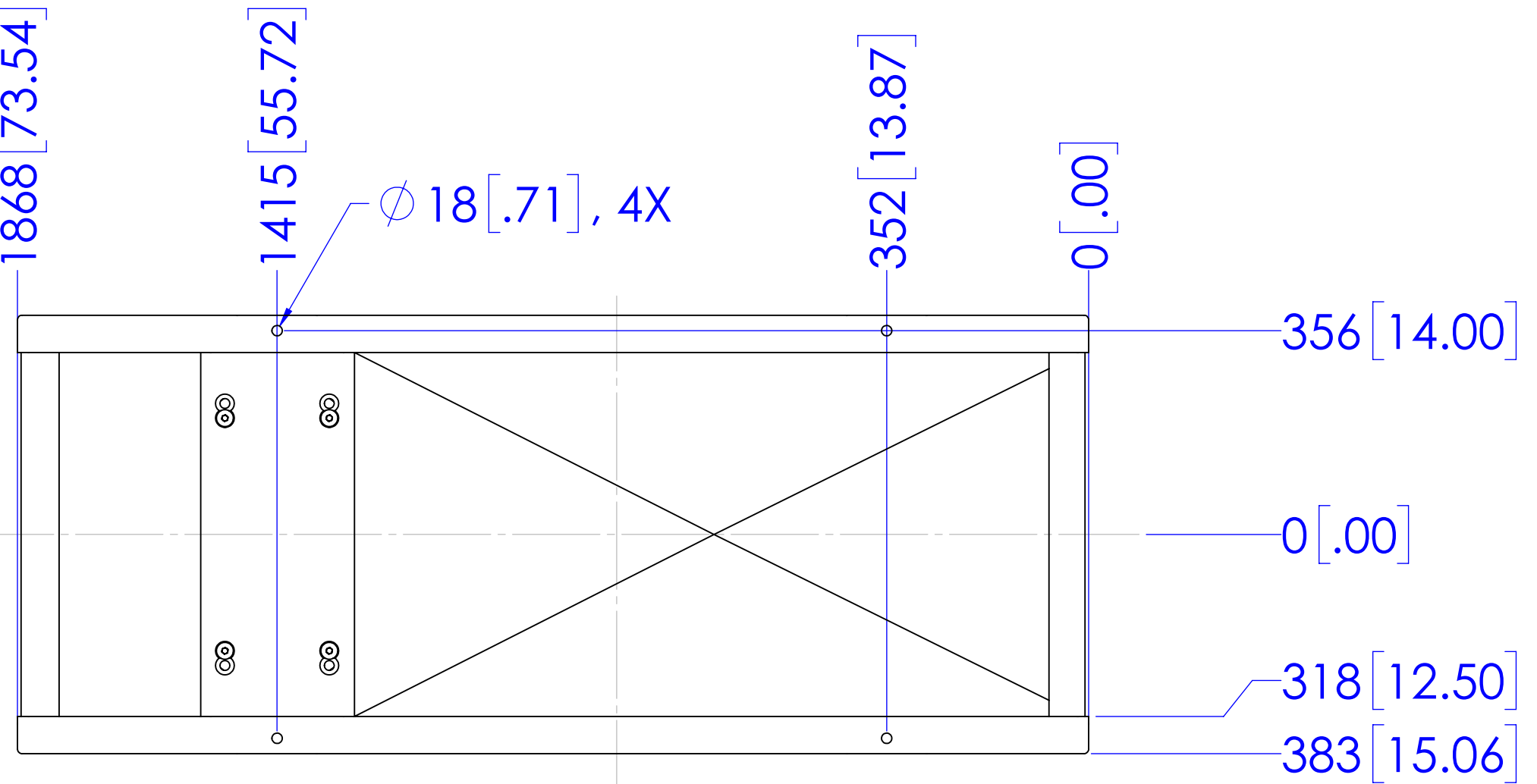

MOUNTING

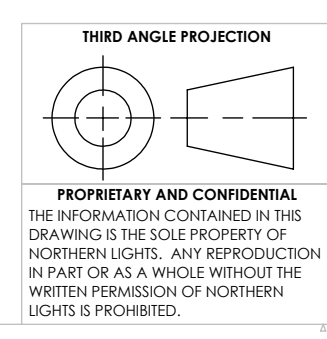

UNLESS OTHERWISE SPECIFIED:		NAME	DATE
DIMENSIONS ARE IN MILLIMETERS		JPW	5/1/2023
TOLERANCES:		CHECKED	MG
ANGULAR: MACH ± 0.5° BEND ± 1.0°		ENG APPR.	
.X ± 0.3		MEG APPR.	
.XX ± 0.3		Q.A.	
INTERPRET GEOMETRIC TOLERANCING PER: ASME Y14.5M		COMMENTS:	
MATERIAL:			
FINISH:			
DO NOT SCALE			

NORTHERN LIGHTS
4420 14th AVE. N.W.
Seattle, WA 98107
(206) 789-3880
www.northern-lights.com

TITLE: INSTALLATION DIMENSIONS
M4105A5.1, 60HZ, LSA 44.3 L10

SIZE	PART NO.	DWG. NO.	REV
D	SEE TABLE	D-5565	

SCALE: 1:10 WEIGHT: SHEET 1 OF 1

REV D D-5565