

PLAN VIEW

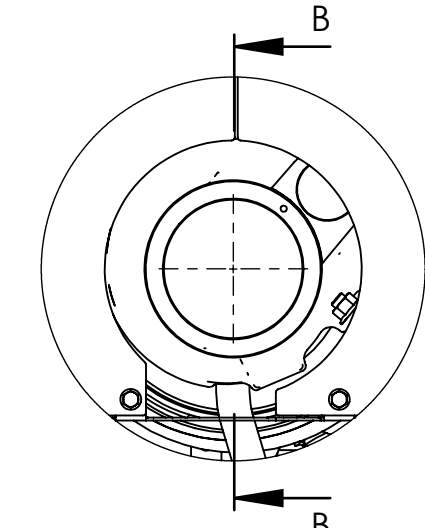

DETAIL A  
SCALE 1 : 5  
EXHAUST CONNECTION

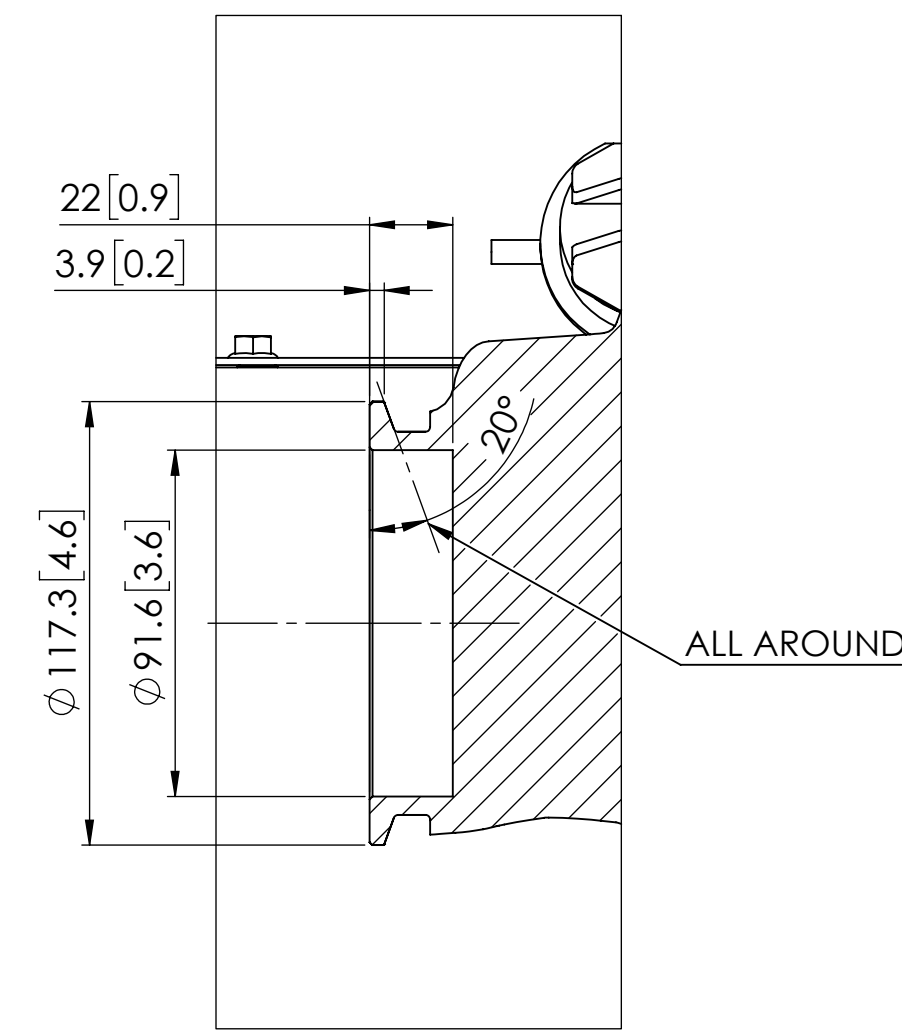

SECTION B-B  
SCALE 1 : 2  
EXHAUST CONNECTION  
DIMENSIONS

P/N	APPLICATION
M1305A32.11 (SHOWN)	250kW@1800RPM 3PH Heat Exchanger Cooled SAE#1/#14 IMO Tier 2
M1305A32.51	250kW@1500RPM 3PH Heat Exchanger Cooled SAE#1/#14 IMO Tier 2
M1305A42.11	300kW@1800RPM 3PH Heat Exchanger Cooled SAE#1/#14 IMO Tier 2

WEIGHT: 2.483 KG [5.475 LB]

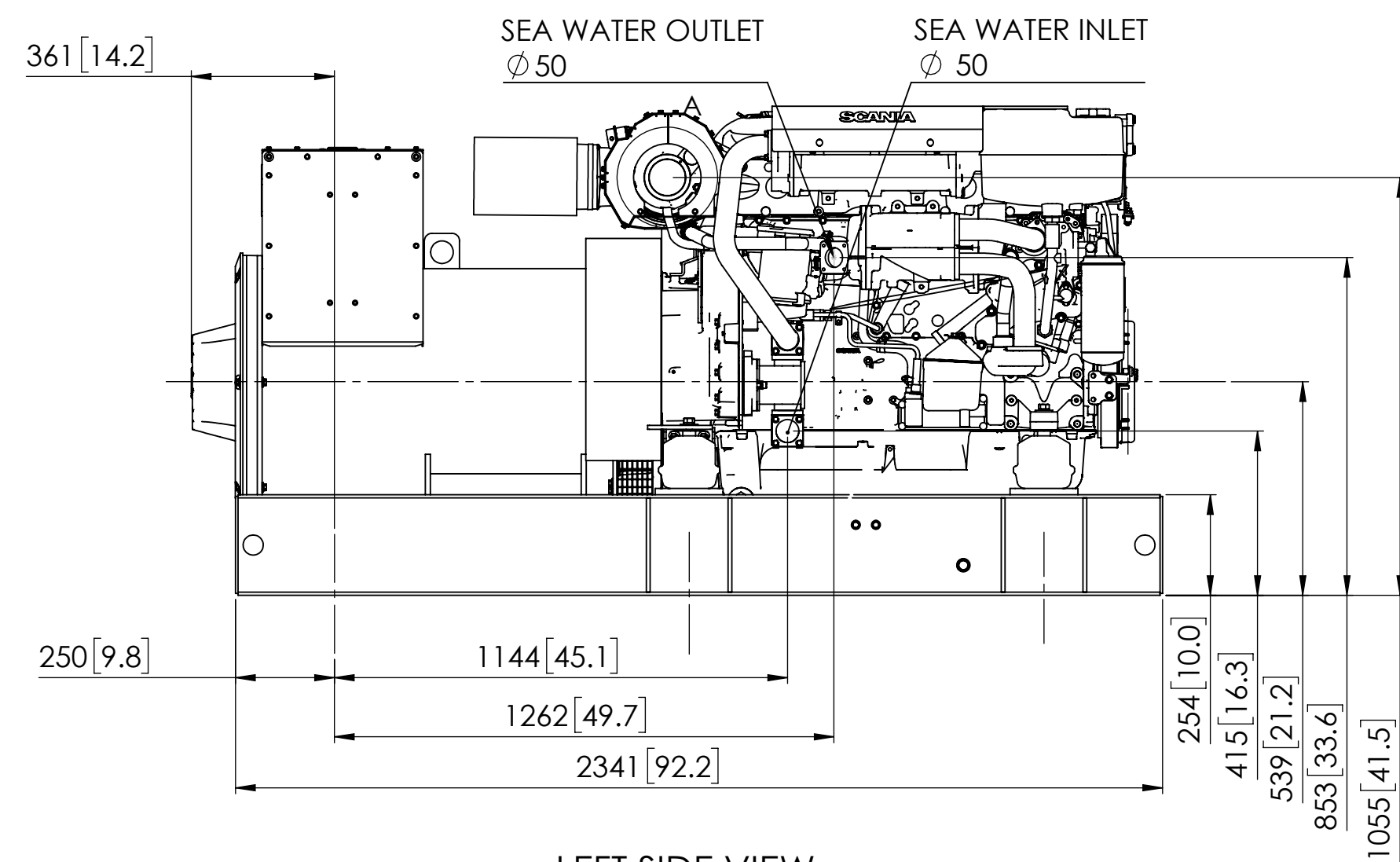

LEFT SIDE VIEW

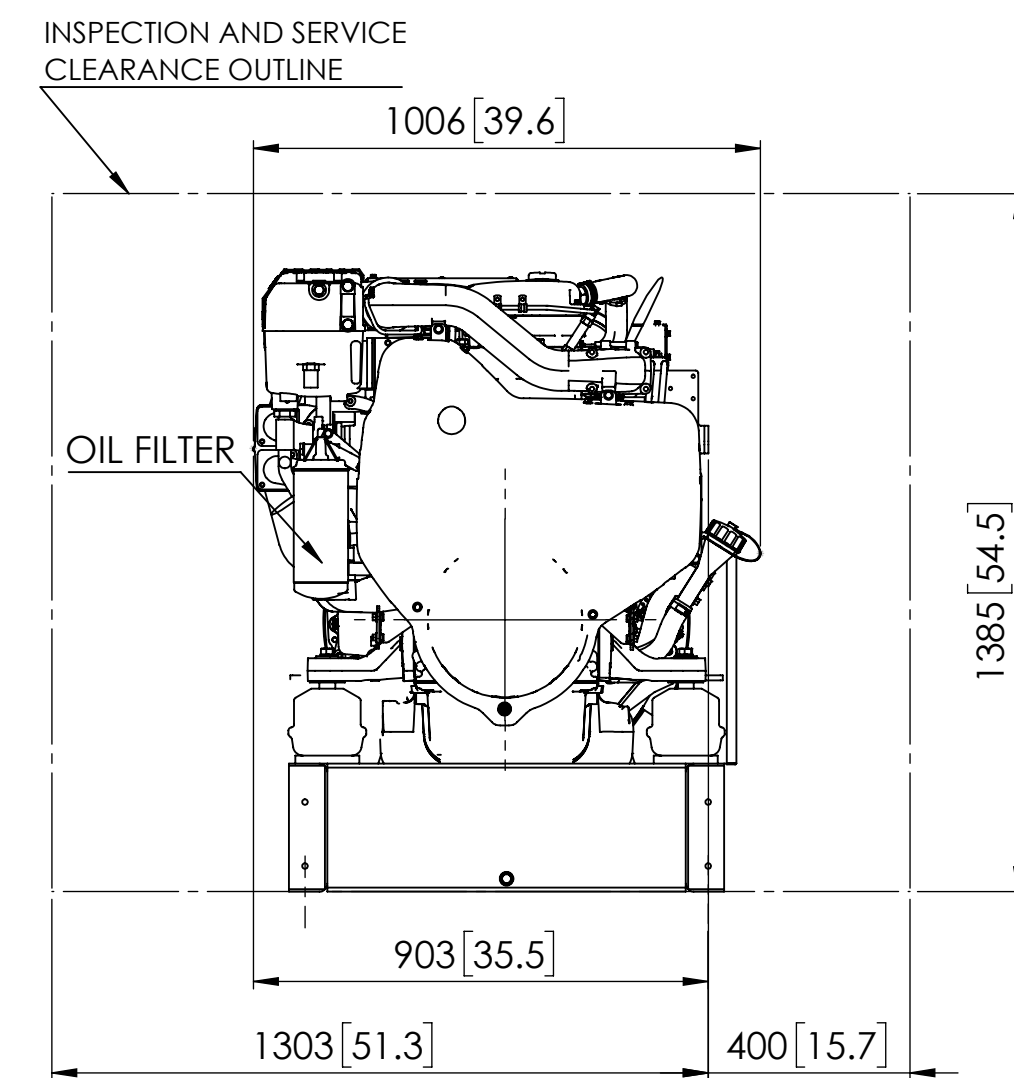

FRONT VIEW

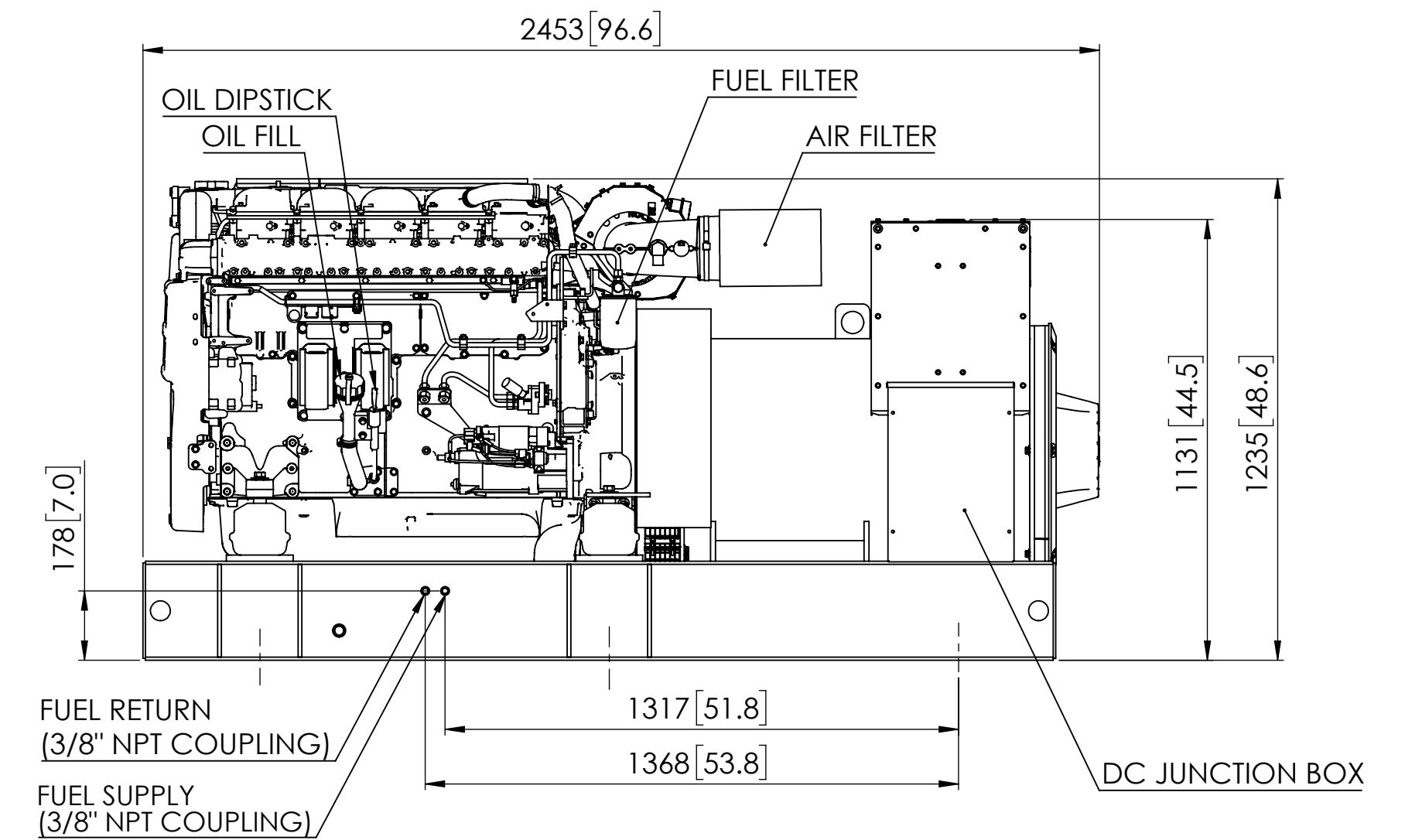

RIGHT (SERVICE) SIDE VIEW

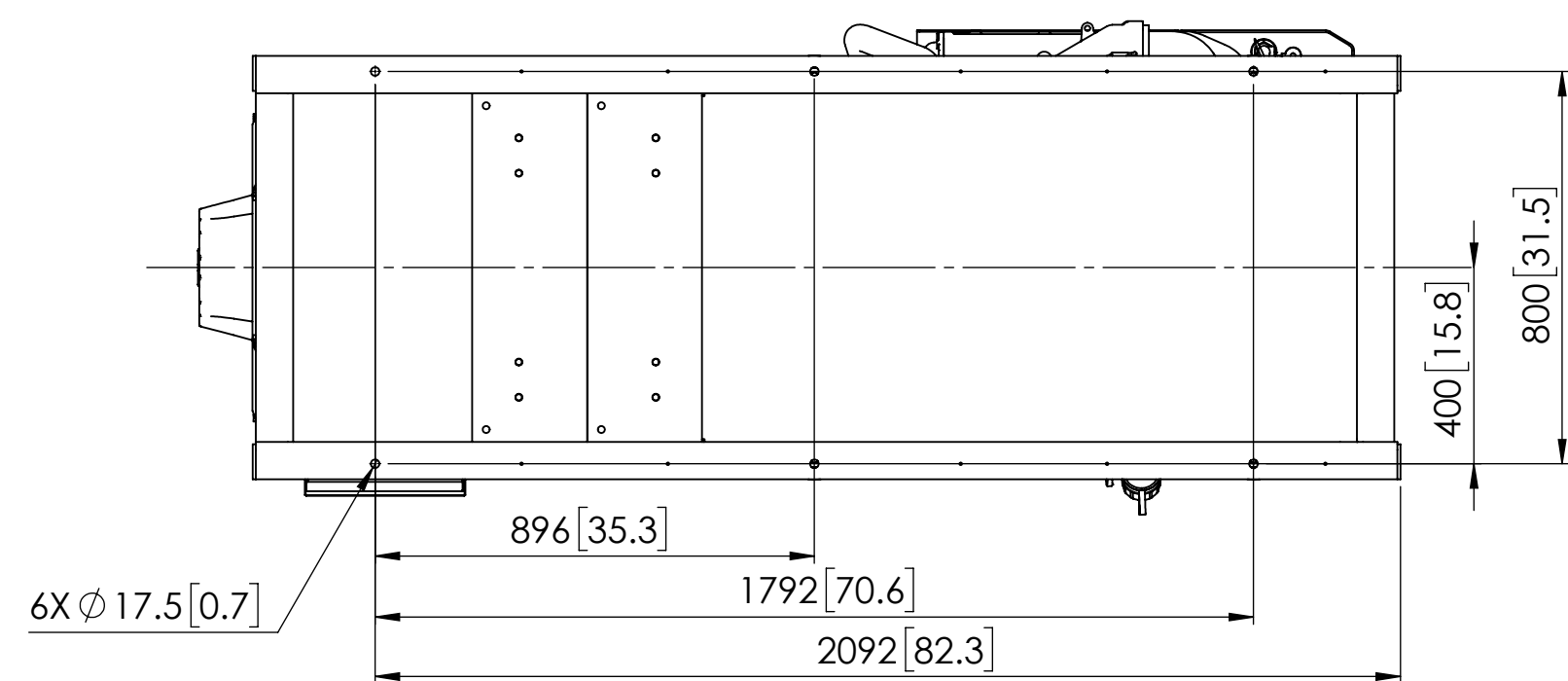

BOTTOM VIEW

THE DIMENSIONS ON THIS DRAWING ARE SUBJECT TO CHANGE. PLEASE CONTACT NLI TO BE SURE YOU HAVE THE MOST CURRENT REVISION

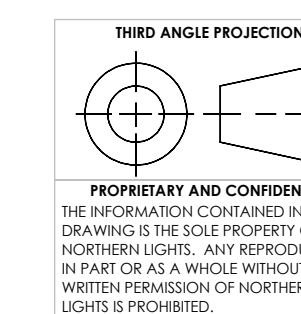

UNLESS OTHERWISE SPECIFIED: DIMENSIONS ARE IN MILLIMETERS TOLERANCES: ANGULAR: ±0.5° HOLE: ±0.1° X: ±1.0°	NAME: AZB DATE: 12/12/16
INTERPRET GEOMETRIC TOLERANCING PER: ASME Y14.5M	CHECKED: TAH DATE: 12/12/16
MATERIAL:	ENG APPR:
FINISH:	MFG APPR:
DO NOT SCALE	Q.A.:
	COMMENTS:

**NORTHERN LIGHTS**

4420 14th AVE. N.W.  
Seattle, WA 98107  
(206) 789-3880  
www.northern-lights.com

TITLE: INSTALLATION DIMENSIONS  
M1305A-2 SERIES (433 GENERATOR END)

SIZE: <b>D</b>	PART NO. SEE P/N TABLE	DWG. NO. D-4987	REV
SCALE: 1:1	WEIGHT:	SHEET 1 OF 1	